

## Impact of floats on water

By N. de DIVITIIS AND L. M. de SOCIO

University of Rome “La Sapienza”, 00184 Rome, Italy

(Received 20 March 2001 and in revised form 4 July 2002)

The impact of a wedge-shaped body on the free surface of a weightless inviscid incompressible liquid is considered. Both symmetrical and unsymmetrical entries at constant velocity are dealt with. The differential problem corresponds to the physico-mathematical model of a distribution of potential singularities and, in particular, the flow singularities at the ends of the wetted regions are represented by sinks. A conformal transformation of the flow field is adopted and the unknown intensities of the discontinuities are found by an optimization procedure, together with the solution of the nonlinear free-surface problem. The flow separation at a sideslip is also considered.

---

### 1. Introduction

Recently, renewed attention has been given to the hydrodynamic action on floats during their entry into water. Apart from the challenging mathematical aspects of the problem, this is due to the renewed interest in large seaplanes in the aircraft world and in very fast marine vehicles in ship building. One of the first models for dealing with the hydrodynamics of a seaplane just after its impact on the water surface was proposed by von Kármán (1929). Much later, significant contributions to the solution of the slamming problem came from naval architects when the full picture of a ship slamming into water began to be considered in all its aspects from the hydrodynamical phenomena to the structural aspects. In this framework the mechanism of the solid surface interaction with the liquid was experimentally observed and theoretically modelled, including such effects as air cushion formation, vortex generation and hydroelasticity.

Faltinsen (1993) presents a good review of the foundations of the slamming problem and their connections with the seakeeping of vessels, where the stresses induced by a water impact can play a very important role. On this last point see, for instance, some recent analytical and numerical solutions in Iafrati *et al.* (2000) and Carcaterra & Ciappi (2000).

Due to the complexity of the impact phenomenology, in most studies it is assumed that the liquid is inviscid and there are no effects of gravity. This means that one of the characteristic parameters which govern the physics of the problem, namely the Froude number, is supposed to be much greater than unity,  $Fr = V_\infty/gt \gg 1$ , and the Reynolds number  $Re = V_\infty^2 t/\nu \rightarrow \infty$ , where  $V_\infty$  is the entry velocity,  $g$  acceleration due to gravity,  $t$  time and  $\nu$  fluid viscosity. This provides a limit on the validity of the results of the theory in terms of the time  $t$ , which must be shortly after the impact, and of the impact speed  $V_\infty$  which must be large.

In most of articles, such as those by von Kármán (1929), Wagner (1932), Dobrovol'skaya (1969), Cointe (1991), Zhao & Faltinsen (1993), Faltinsen & Zhao (1997), the reference shape of the float is assumed to be a wedge that is usually supposed to have its symmetry plane normal to the free water surface.

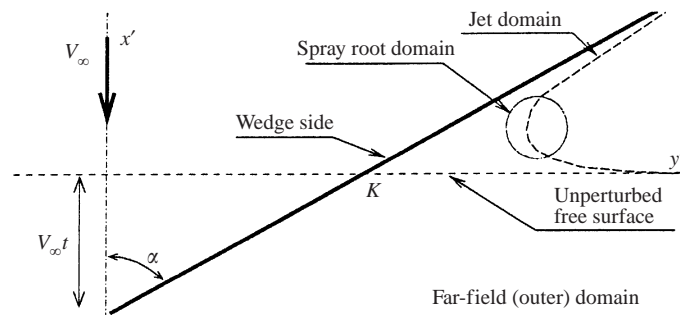

FIGURE 1. Proposed subdomains.

A number of papers deal with the entry of blunt bodies. When this is the case, a simple approach is to assume that the first impact is that of a flat plate (Moghishi & Squire 1981; Cointe 1987; Howison, Ockendon & Wilson 1991). It was shown that Wagner's solution for a wedge-shaped body also applies to arbitrary blunt bodies, provided that the wetted length is properly computed. Also interesting is the fact that the asymptotic solution for the wedge entry problem is a particular example of the more general asymptotic approach for blunt bodies. Present trends in naval research follow more complex procedures than the flat plate approach when dealing with blunt geometries but they are beyond the scope of this paper.

The symmetric impact of a wedge-shaped float can be divided in two phases. Initially the point of contact  $K$  (figure 1) between the wall and the unperturbed free surface may move at a velocity  $V_K$  greater than the speed of sound in the liquid  $c_w$ . In particular  $V_K = V_\infty / \cos \alpha$ , where  $\alpha$  is the wedge semi-angle and  $V_\infty$  is the entry velocity. After the very first instants, however,  $V_K$  slows down to subsonic values. The supersonic and the subsonic phases are, of course, treated in different ways. When a supersonic phase occurs it is generally dealt with within an acoustic approximation (see Skalak & Feit 1966; Korobkin 1992) which is sufficiently accurate in applications where the Mach number of point  $K$ , namely  $V_K/c_w$ , is a little greater than unity.

The subsonic case of an incompressible fluid, which is the subject of the present paper, has a series of interesting features associated with the complicated configuration of the flow field and the nonlinear aspects of the mathematical problem due to the presence of a free surface.

Figure 1 shows the subdomains into which the water region can be divided according to Wagner's (1932) first ideas, the first quantitatively correct version of Howison *et al.* (1991) and then Cointe (1991), Zhao & Faltinsen (1993) and Faltinsen & Zhao (1997); this figure helps in understanding the physical characteristics of the field. The sketch also indicates the reasons for some of the approximate solution procedures which were adopted in the past. In particular one can see the presence of a close field with sizeable effects on the impact, a far field of negligible perturbations, and two lateral jets. These jet subdomains, first described by Wagner (1932), Howison *et al.* (1991) and then by Cointe (1991) and others, are the regions where portions of the liquid initially run close to the wall and then lose their continuum fluid identities and form mists, sprays or, in general, two-phase flows.

When considering the existing literature, recall that solutions to the subsonic incompressible problem have appeared frequently, using different either approximate or numerical approaches. For a constant entry velocity into an inviscid and weight-

less liquid, approximate analytical solutions have been proposed which are similar with respect to the time  $t$ . In particular the two-dimensional Laplace equation for the velocity potential was initially solved by Wagner (1932) in the case of a wedge of very small vertex angle. Much later Dobrovol'skaya (1969) reduced the problem of the complex potential to a nonlinear singular integral equation which was solved by a method of successive approximations. Subsequently, a solution to this equation was found by Zhao & Faltinsen (1993) by a nonlinear boundary elements method. These authors also pointed some the errors in Dobrovol'skaya (1969) data.

On the other hand, for large values of  $\alpha < \pi/2$ , Korobkin & Pukhnachov (1988) used a variational approach, which was later followed by Howison *et al.* (1991), for an asymptotic analysis. In addition Fraenkel & McLeod (1997) carried out an asymptotic analysis for  $\alpha = \pi/2 - \epsilon$ , after a conformal transformation of the field. Almost at the same time Fontaine & Cointe (1997) published a summary of the approximate (for large  $\alpha$ ) results and proposed composite solutions which are based on a division of the flow field analogous to the one in figure 1.

A conformal mapping method, which involves the Wagner's function, was used by Hughes (1972) to solve the water entry problem of a wedge by a mixed analytical and numerical procedure. The method reduces the problem to the calculation of a mapping function for the hodograph.

The impact may not be symmetrical for different reasons: the symmetry plane of the wedge is normal to the free surface whereas the entry velocity is not; or the entry velocity is normal to the free surface and the symmetry plane is not. A few authors speculated about possible approaches to the situation of a wedge plunging into the water at a sideslip angle, but no calculated solutions were presented (Wagner 1932; Dobrovol'skaya 1969). The particular case of flow separation was considered by Zhao, Faltinsen & Aarsnes (1997) in the framework of a simulation study on the entry of two-dimensional bodies of arbitrary cross-sections. They dealt with the problem of flow separation from knuckles or fixed separation points on both sides of symmetric bodies. In particular, the Kutta condition is applied at a separation point. In the second case of an asymmetric water entry, where a wedge plunges normal to the free surface but with the velocity vector at an angle with respect to the symmetry plane, Toyama (1993) presented a solution obtained through a finite element method.

Morgan (1994) gave an explanation of Trefethen & Panton's (1990) observation that an impact splash is largely independent of the horizontal speed of the impacting body, when the horizontal velocity component is comparable with the downward velocity.

Here, after proposing a model of the wedge slamming problem which is based on a suitable distribution of the velocity potential, we find excellent solutions of that model for the flow field following an optimization procedure for solving an algebraic set of equations. The shape of the free surface and the pressure coefficient distribution along the wetted walls will be considered in cases of both symmetrical and non-symmetrical impact. In the latter case, in the presence of sideslip, we obtain the solution in the two situations of a flow which is either attached to both faces of the float or separates downstream from the leading edge. Moreover a condition for flow separation will be introduced.

As in some of the cited references, conformal transformations will be used, although in our case the external hydrodynamical problem in the semi-infinite physical plane will be transferred to part of the interior of a circle in the transformed plane. The solutions will be compared with the existing ones where available.

## 2. Analysis of the two-dimensional impact

Let us again consider figure 1. A preliminary observation suggests a reasonable mathematical model of the physics of slamming, which is based on a distribution of singularities in a steady potential field. For a constant velocity  $V_\infty$ , an appropriate transformation of the  $x'$ - and  $y'$ -coordinates into the dimensionless ones,  $x = x'/V_\infty t$  and  $y = y'/V_\infty t$ , makes the problem similar with respect to the time  $t$  and steady in the new coordinate plane  $(x, y)$ . It is convenient to take the body at rest while the water level moves upward, and this assumption justifies why the calculated iso- $\psi$  lines, in the present model, end at the free surface.

At the walls the normal component of the flow velocity is zero whereas the perturbing effects of the body impact vanish in all directions at an infinite distance from the wedge. Let the free surface be represented in the plane  $(x, y)$  by the line  $x = \bar{x}(s), y = \bar{y}(s)$ . The unknown shape of this curve, which makes the differential problem nonlinear, is to be determined by imposing that the pressure coefficient  $C_p$  at the free surface must be zero and that its perturbation from the unperturbed straight line goes to zero as  $s$  goes to infinity. As we will see, both these conditions can be satisfied provided that a jet of finite flow rate, also to be determined, is present close to the body, on each side. A contact iso- $\psi$  line separates the jet from the rest of the flow. For the case where the flow separates from one side some further considerations will be presented later.

As already observed in previous works, the potential flow field in an incompressible weightless fluid presents similar solutions in the transformed coordinates  $x, y$ , provided that the velocity potential  $\Phi$  and the streamfunction  $\Psi$  are expressed in the dimensionless transformed forms  $\varphi$  and  $\psi$ :

$$\Phi(x', y', t) = V_\infty^2 t \varphi(x, y), \quad \Psi(x', y', t) = V_\infty^2 t \psi(x, y). \quad (2.1)$$

Then the velocity  $(u', v')$  of the flow field, expressed as the gradient of  $\Phi$ , has the form

$$(u', v') \equiv \left( \frac{\partial \Phi}{\partial x'}, \frac{\partial \Phi}{\partial y'} \right) = V_\infty \mathbf{v}, \quad (2.2)$$

with  $\mathbf{v} \equiv (u, v) = (\partial \varphi / \partial x, \partial \varphi / \partial y)$ . The differential problem represented by the Laplace equation and associated boundary conditions will be solved by taking advantage of the conformal transformations in the situations which are sketched in figures 2 and 3. Note that, for convenience, we have assumed a circle in the complex plane for the transformed physical water region.

Figure 2 shows a flow field where the fluid is attached to both sides of the wedge in an unsymmetrical water entry, of which a symmetrical situation is a particular case. Figure 3 corresponds to the circumstance where the flow separates from one side when the float enters at a sideslip angle  $\beta$ .

Let  $z = x + iy$  be the physical plane and  $\zeta = \xi + i\eta$  the complex plane onto which  $z$  is conformally transformed, with the walls of the wedge becoming arcs of a circle the centre of which,  $O$ , corresponds to the upstream infinity. Let the complex potential  $f = \varphi + i\psi$  be defined on  $\zeta$ . Corresponding points of the two planes are represented by the same capital letters with a prime for the points on  $z$ . In all cases, points  $A'$  and  $P'$  refer to the stagnation point and to wedge vertex, respectively, and so do their transformed representations  $A$  and  $P$ . Between  $B$  and  $O$  and between  $D$  and  $O$  lie the unknown lines which represent the two branches of the free surface.

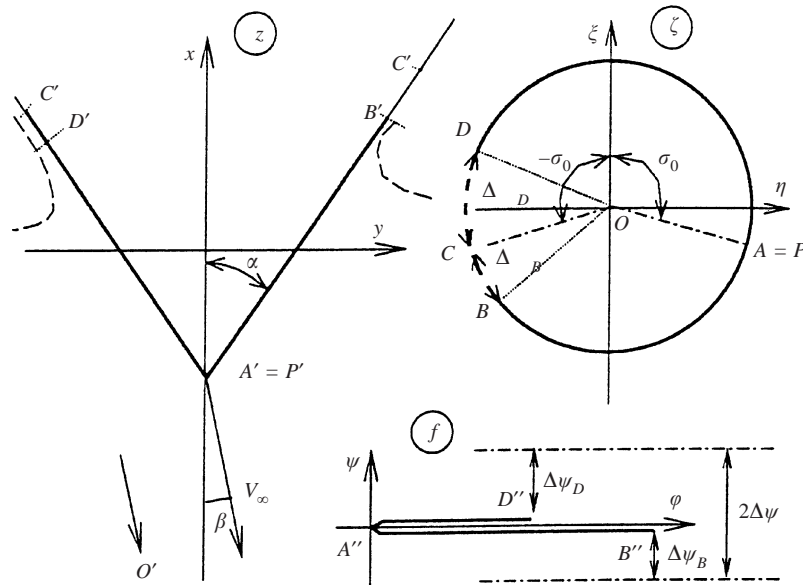

FIGURE 2. Conformal mapping (attached flow).

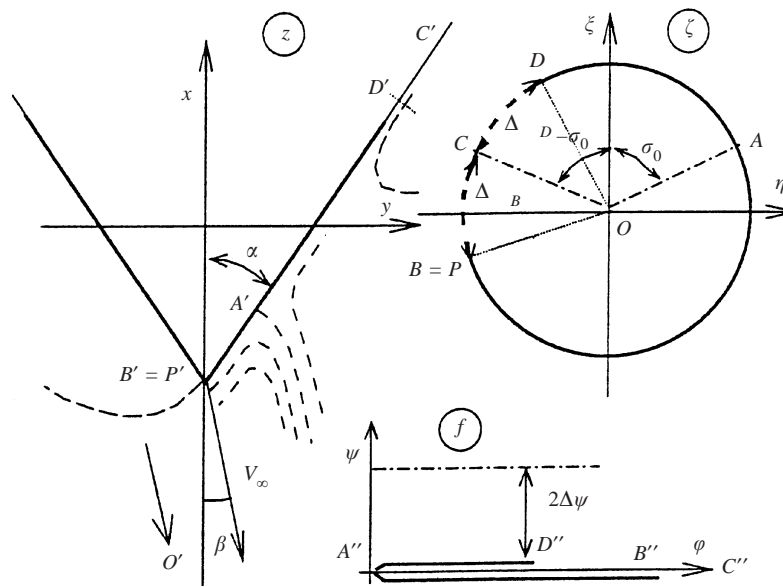

FIGURE 3. Conformal mapping (separated flow).

The general model of the flow field corresponds to the sum of a number of singularities of the velocity potential, the intensities of which are to be determined in accordance with the physical conditions.

As already mentioned, the conditions on the physical plane  $z$  correspond to a vanishing normal component of the velocity along the lines  $A'B'$  and  $A'D'$ , whereas  $C_p = 0$  at all the points of the free surface, including  $B'$  and  $D'$ . In particular, this last point represents an excellent assumption for small and intermediate deadrise angles and is still a good approximation for  $\alpha$  as low as  $9^\circ$ .

The meanings and the locations of the singularities are quite easily understood. There is a doublet at  $O$  for the translational potential. More attention has to be paid to the singularities which provide the simulation of the lateral jets. In this case each jet is represented by a sink and a distorted doublet at, for example, point  $C'$ , in such a way that the necessary jump of the streamfunction  $\Delta\psi$  is obtained, while the condition  $C_p = 0$  is satisfied at both  $B'$  and  $D'$ . A free vortex at  $O$  provides a finite value of the fluid velocity on the apex of the wedge in the case of sideslip.

With reference to the  $\zeta$ -plane, the complex potential must satisfy the following conditions:  $f$  must be real on the arc  $DAB$  and its real part must monotonically increase from  $A$  to  $B$  and from  $A$  to  $D$ , and go to infinity at  $C$  and  $O$ . Points  $A$ ,  $B$ ,  $C$  and  $D$  will be transformed into  $A''$ ,  $B''$ ,  $C''$  and  $D''$  on the  $f$ -plane where a cut is present on the horizontal axis  $\varphi$  with the two branches corresponding to the two sides of the same iso- $\psi$  line which are divided by the stagnation point  $A'$ . Points  $B$  and  $D$ , to be determined, represent the traces of the line along which  $C_p = 0$  on the wedge. Finally, the angles  $\Delta\vartheta_B$  and  $\Delta\vartheta_D$  correspond to the arcs  $BC$  and  $CD$ , respectively. Since the transformed free-surface lines on  $\zeta$  are lines which connect  $O$  with  $B$  and  $C$ , the transformed domain is the finite region bordered by the unit circle less the sector between  $B$ ,  $O$  and  $D$ .

The complex potential that satisfies all the required conditions will be obtained by applying the Schwarz–Christoffel method. Let us then assume an expression for  $f$  which is the sum of five terms

$$f = \lambda_0 + \lambda_1 \frac{i}{2} \left( \zeta - \frac{1}{\zeta} \right) + \frac{\Delta\psi}{\pi} \ln \left( 1 - \frac{1}{2} i \left( q\zeta - \frac{1}{q\zeta} \right) \right) + \chi \frac{q\zeta + 1/q\zeta}{1 - \frac{1}{2} i (q\zeta - 1/q\zeta)} - i\Gamma \ln \zeta, \quad (2.3)$$

where  $\sigma_0 = \pi/2(1 + \beta/\alpha)$  and  $q = \exp(i(\sigma_0 - \pi/2))$ .

The five terms in (2.3) are (a) a constant  $\lambda_0$  which is associated to the presence of a free surface; (b) a doublet placed at  $O$  of intensity  $\lambda_1$  which corresponds to the translational flow in the physical plane; (c) a sink at  $C$  of intensity  $2\Delta\psi = \Delta\psi_B + \Delta\psi_D$ , that depends on the angle  $\alpha$  and on the sideslip  $\beta$ ; (d) a distorted doublet, also at  $C$ , that depends on  $\beta$ ; (e) a free vortex of intensity  $\Gamma$  on the border at  $O$ .  $\chi$  and  $\Gamma$  are zero in the symmetric case. The sum of the flow rates of the two jets corresponds to  $2\Delta\psi$ . When the flow is not symmetric, the two flow rates  $\Delta\psi_B$  and  $\Delta\psi_D$  are different and, in terms of the complex potential, this partition is associated with the doublet  $\chi$  in (2.3). The presence of  $\Gamma$  at infinity in  $O$  does not yield vorticity in the field.

The properties of the complex velocity  $w = (df/d\zeta)/(d\zeta/dz) = u - iv$  on the physical plane  $z$  need to be considered in order to complete the formulation of the problem and to recover the shape of the free surface once the problem in the transformed plane has been solved. In this respect it is useful to express the complex velocity through the so-called Levi–Civita auxiliary function  $\omega(\zeta)$  (see Cisotti 1921) such that  $w(\zeta) = \exp[-i\omega(\zeta)]$ . In particular  $w$  must be zero at  $A$  and its modulus must increase monotonically from  $A$  to  $B$  and from  $A$  to  $D$ , taking a unit value at  $O$ , and its real and imaginary parts must satisfy the condition of null normal velocity on the circle on  $\zeta$ .

The auxiliary function  $\omega(\zeta)$  which satisfies the kinematic condition at the wall of the wedge is obtained by the Schwarz–Christoffel formula

$$\omega(\zeta) = \beta - \alpha + \frac{2i\alpha}{\pi} \log \left( \frac{\zeta - j}{1 - j\zeta} \right), \quad j = \exp(i\sigma_0). \quad (2.4)$$

All the points on the physical plane are then obtained through the quadrature formula

$$z(\zeta) = z(\zeta_0) + \int_{\zeta_0}^{\zeta} e^{i\omega(\zeta)} \frac{df(\zeta)}{d\zeta} d\zeta \tag{2.5}$$

that gives the anti-transformation of the  $\zeta$ -plane onto the physical plane.

Returning to the evaluation of the five unknown constants, reference must be made to conditions which are meaningful from the physical point of view. First, mass continuity, momentum balance and energy conservation must be satisfied. Moreover a condition (to be discussed later) must be imposed on the flow characteristics around the wedge apex when  $\beta \neq 0$ .

Volume conservation takes into account the contributions of the free-surface displacement from the unperturbed free surface, as the wedge penetrates into the liquid, and the flow rates of the jets. The free surface is like a material surface along which the pressure coefficient  $C_p$  is zero, that is not perturbed at infinity and that ends at the contact iso- $\psi$  lines of the lateral jets. Let  $A_i$  be the immersed float area. The pertinent condition is

$$R_1 \equiv \int_B^{\infty} \bar{x}(s) \frac{d\bar{y}(s)}{ds} ds + \int_D^{\infty} \bar{x}(s) \frac{d\bar{y}(s)}{ds} ds + \frac{\Delta\psi_B + \Delta\psi_D}{2} - A_i = 0. \tag{2.6}$$

The Bernoulli theorem, following relations (2.1) and (2.2), states that  $\partial\Phi/\partial t = (\varphi - \mathbf{r} \cdot \mathbf{v})V_{\infty}^2$ . Then the expression for the pressure coefficient becomes  $C_p = 1 - \mathbf{v} \cdot \mathbf{v} - 2(\varphi - \mathbf{r} \cdot \mathbf{v})$ , where  $\mathbf{r}$  is the distance of a point  $(x, y)$  of the flow field from the apex  $P'$ . Therefore the condition to be imposed at all points of the free surface is

$$1 - \mathbf{v} \cdot \mathbf{v} - 2(\varphi - \bar{\mathbf{r}} \cdot \mathbf{v}) = 0, \tag{2.7}$$

where  $\bar{\mathbf{r}}$  is the distance of a point of the free surface  $(\bar{x}, \bar{y})$  from  $P'$ .

Two further scalar conditions come from the momentum balance and state that the integral of the pressure distribution on the body surface  $S_B$  must be equal to the time-derivative of the momentum, including the effects of the lateral jets,

$$(R_2, R_3) \equiv \int_{S_B} (p - p_{\infty}) \mathbf{n} dS + \frac{d}{dt} \int_S \rho \varphi \mathbf{n} dS + \Delta\mathbf{q}_{B'} + \Delta\mathbf{q}_{D'} = 0, \tag{2.8}$$

where  $\Delta\mathbf{q}_{B'}$  and  $\Delta\mathbf{q}_{D'}$  are the contributions of the lateral jets. Since the structure of a jet is modelled as a sink through which mass, momentum and energy disappear then, in particular, the lost momentum  $\Delta\mathbf{q}$  and energy  $\Delta E$  can be evaluated by means of the developed jet approximation

$$\Delta\mathbf{q} = \int_{\Delta\psi} (\mathbf{v} - \mathbf{r}) d\psi \approx \Delta\psi(V - \mathbf{r})\mathbf{t},$$

$$\Delta E = \frac{1}{2} \int_{\Delta\psi} (\mathbf{v} - \mathbf{r}) \cdot (\mathbf{v} - \mathbf{r}) d\psi \approx \frac{1}{2} \Delta\psi(V - r)^2,$$

where  $\mathbf{t}$  is the unit vector parallel to the wedge side. At small deadrise angle  $\delta$  the jet approximation is satisfied in the limit  $\delta \rightarrow 0$  while at  $\delta \rightarrow 90^\circ$  both the exact and the approximate expressions give  $\Delta\mathbf{q} \rightarrow 0$ ,  $\Delta E \rightarrow 0$ , since  $\Delta\psi \rightarrow 0$ . At intermediate deadrise angle the jet approximation might involve greater errors but the calculation performed and presented here give results which are in excellent agreement with the existing data of Zhao & Faltinsen (1993).

With reference then to (2.8) one has

$$\Delta \mathbf{q}_{B'} = \int_{\Delta \psi_{B'}} (\mathbf{v} - \mathbf{r}) d\psi \approx \Delta \psi_{B'} (V_{B'} - r_{B'}) \mathbf{t}_{B'}$$

and

$$\Delta \mathbf{q}_{D'} = \int_{\Delta \psi_{D'}} (\mathbf{v} - \mathbf{r}) d\psi \approx \Delta \psi_{D'} (V_{D'} - r_{D'}) \mathbf{t}_{D'}$$

where, as before,  $\mathbf{t}_{B'}$  and  $\mathbf{t}_{D'}$  are the local tangent unit vectors, and  $r_{B'}$  and  $r_{D'}$  are the distances from the apex of the wedge to the points  $B'$  and  $D'$ , respectively.

Note that the derivative of the momentum for a constant entry velocity is due to the variation of the apparent additional mass. Note also that in the proper dimensionless similarity variables  $r_{B'}$  and  $r_{D'}$  are also the velocities of the points  $B'$  and  $D'$ .

The lateral surface of the wedge depends on  $\Delta \vartheta_B$  and  $\Delta \vartheta_D$  through

$$S_B(\Delta \vartheta_B, \Delta \vartheta_D) = \int_{\sigma_0 + \Delta \vartheta_B}^{2\pi - \sigma_0 - \Delta \vartheta_D} \left| \frac{df}{d\zeta} \right| \frac{1}{|w|} d\vartheta,$$

and  $S$  is where  $S_B$  meets the free surface.

The energy conservation takes into account the presence of the free surface and of the jets and equates the work of the hydrodynamic force on the body to the time derivative of the kinetic energy:

$$R_4 \equiv \int_{S_B} (p - p_\infty) \mathbf{V}_\infty \cdot \mathbf{n} dS - \frac{1}{2} \frac{d}{dt} \int_S \rho \varphi \nabla \varphi \cdot \mathbf{n} dS + \Delta E_{B'} + \Delta E_{D'} = 0, \quad (2.9)$$

where, as before,

$$\Delta E_{B'} = \frac{1}{2} \int_{\Delta \psi_{B'}} (\mathbf{v} - \mathbf{r}) \cdot (\mathbf{v} - \mathbf{r}) d\psi \approx \frac{1}{2} \Delta \psi_{B'} (V_{B'} - r_{B'})^2$$

and

$$\Delta E_{D'} = \frac{1}{2} \int_{\Delta \psi_{D'}} (\mathbf{v} - \mathbf{r}) \cdot (\mathbf{v} - \mathbf{r}) d\psi \approx \frac{1}{2} \Delta \psi_{D'} (V_{D'} - r_{D'})^2$$

are the kinetic energy terms which are lost through the lateral jets.

It is worth remarking that since the expressions for  $\Delta \mathbf{q}$  and  $\Delta E$  were obtained under the approximation of a developed jet, they do not allow a fully detailed description of the flow structure near the walls.

Whereas for  $\beta = 0$  the stagnation point  $A'$  falls on the apex, two possible choices can instead be made for  $\beta \neq 0$ : either point  $A'$  is still coincident with the apex (figure 2) and no separation occurs, or the free surface separates downstream from the apex, and  $A'$  moves along the upstream wet side of the wedge (figure 3). In both cases one has the further condition  $df/d\zeta = 0$  in  $\zeta_A$ , i.e.

$$R_5 \equiv \Gamma - \lambda_1 \cos \sigma_0 + \frac{\Delta \psi / \pi \cos(\sigma_0 + \varepsilon) + 2\chi}{1 + \sin(\sigma_0 + \varepsilon)} = 0, \quad (2.10)$$

where  $\varepsilon = \sigma_0 - \pi/2$ . In the expressions for  $R_1$  to  $R_5$  above a few auxiliary unknowns appear, namely the angles  $\Delta \vartheta_B$ ,  $\Delta \vartheta_D$  and the jumps of the streamfunction  $\Delta \psi_{B'}$  and  $\Delta \psi_{D'}$ .

Let us discuss the attached case first. The conditions

$$R_6 \equiv C_{p_{B'}} = 0, \quad R_7 \equiv C_{p_{D'}} = 0 \quad (2.11)$$



give the values of  $\Delta\vartheta_B$  and  $\Delta\vartheta_D$  and the total flow rate of the two jets  $2\Delta\psi$  is divided in such a way that

$$R_8 \equiv 2\Delta\psi - (\Delta\psi_{B'} + \Delta\psi_{D'}) = 0. \tag{2.12}$$

As has been seen, in the case of attached flow the volume flow rates of the lateral jets correspond to two jumps of the streamfunction. The Bernoulli equation for each contact iso- $\psi$  line which comes from infinity gives

$$R_9 \equiv \frac{\Delta\psi_{B'}}{\Delta\psi_{D'}} - \frac{V_{B'}^2 - 1}{V_{D'}^2 - 1} = 0, \tag{2.13}$$

where  $V_{B'}$  and  $V_{D'}$  are evaluated as  $|w(\zeta_B)|$  and  $|w(\zeta_D)|$  respectively, since the potential time derivatives are recognized to be  $(\partial\varphi/\partial t)|_{B'} = \text{const } \Delta\psi_{B'}$  and  $(\partial\varphi/\partial t)|_{D'} = \text{const } \Delta\psi_{D'}$ .

When we consider the case of a separated flow, the problem reduces to that of a flat plate entering the water at an angle  $2\pi - (\alpha + \beta)$ . One of the two streamfunction jumps is zero and instead of (2.13), the condition that the apex of the wedge is a point of separation is applied:

$$R_9 \equiv \frac{df(\zeta_P)}{d\zeta} = 0. \tag{2.14}$$

We finally turn our attention to the shape of the free surface in the physical plane. The kinematic condition on that surface is

$$\frac{d\mathbf{r}}{ds} = \frac{\mathbf{r} - \mathbf{v}}{\sqrt{(x - u)^2 + (y - v)^2}}, \tag{2.15}$$

where (2.7) must be satisfied also. The vector equation (2.15) expresses the fact that the free surface is always made up of the same particles. Equation (2.15) when combined with (2.7) confirms that the arc distance between two particles on the surface is constant (see, for instance, Birkhoff & Zarantonello 1957; Mackie 1962).

Introducing the complex notation we obtain, in the transformed variables, the quadrature equations from (2.15) and (2.7):

$$z(\zeta) = z_i + \int_{\zeta_i}^{\zeta} \frac{z(\zeta') - w^*(\zeta')}{\sqrt{(x(\zeta') - u(\zeta'))^2 + (y(\zeta') - v(\zeta'))^2}} |z_\zeta(\zeta')| d|\zeta'| \quad (i = B', D'), \tag{2.16}$$

where the integrals are restricted to the paths on  $\zeta$  that correspond to  $C_p = 0$ . The most difficult part of the differential problem, i.e. the determination of the shape of the free surface, is thus formally reduced to the integration of expressions (2.16) along the paths along which  $C_p = 0$ .

### 3. The algorithm

Expressions (2.6)–(2.13) (or (2.6)–(2.12), (2.14)) represent an algebraic system with nine unknown parameters. Among the various solution methods, a speedy and easy way was adopted which corresponds to solving the problem in the form of a residual function

$$R(\lambda_0, \lambda_1, \Delta\psi, \chi, \Gamma, \Delta\psi_B, \Delta\psi_D, \Delta\vartheta_B, \Delta\vartheta_D) = \sum_{i=1}^9 R_i^2$$

which is made zero through an optimization procedure. In particular the optimization method by Davidon, Fletcher and Powell was adopted which is a numerical code in the widely known NAG library (Numerical Algorithms Group 1991).

In detail, the steps of the algorithm to obtain the solution in the physical plane are as follows.

(i) The analytical form of the complex potential (2.3) that satisfies all the required boundary conditions is assumed.

(ii) As a first guess values of all the nine parameters  $\lambda_0, \lambda_1, \Delta\psi, \chi, \Gamma, \Delta\psi_B, \Delta\psi_D, \Delta\vartheta_B, \Delta\vartheta_D$  are chosen. Therefore the complex potential velocity is completely defined in the  $\zeta$ -plane.

(iii) All the points on the physical plane are calculated via (2.5), so that a first approximation to the solution which describes the flow around the wedge is evaluated.

(iv) If the solution so obtained satisfies the algebraic set and makes function  $R$  go to zero, the procedure is terminated and the physical solution has been found. Otherwise, the optimization process will update the nine parameters in such a way that  $R$  is minimized and the procedure will be repeated from step (iii).

(v) Once the parameters which comprise  $\sum_{i=1}^9 R_i^2 = 0$  are evaluated, next step is to calculate the shape of the free surface through integration of (2.16). To this end, in this work a routine fourth-order Runge–Kutta method was adopted.

#### 4. Results

Some results will now be presented and discussed. First, some solutions obtained in this paper were substituted, for comparison, into the singular integral equation obtained in Dobrovol'skaya (1969) for the symmetric case and it was solved by a finite difference method. In particular, for  $\beta = 0$ , we considered the cases where  $\alpha = 60^\circ$  and  $70^\circ$  which were thought to represent good tests for the solution procedure. In fact these intermediate values of  $\alpha$  correspond to situations which are far from the limits where the existing approximate solutions are accurate enough. Therefore our solutions were substituted into Dobrovol'skaya's integral equation at a number of points of the liquid domain and of the wetted surface and the results with negligible differences corresponded to the data reported in Dobrovol'skaya (1969) as corrected by Zhao & Faltinsen (1993).

After proving the reliability of the method, the situations considered in Zhao & Faltinsen (1993) which were solved there by a nonlinear boundary elements method were dealt with by the present approach. Again, an excellent agreement was found between the two procedures, apart from negligible numerical errors. The results for the cases cited above are given in figure 4 where some iso- $\psi$  lines are sketched both in the physical and in the transformed plane. The calculated  $C_p$  vs.  $x$  along the walls is shown in figure 5. The calculations proved that the present analysis provides excellent solutions in a very simple and fast way over the entire range of  $\alpha$ , the case  $\alpha = 0$  and  $\alpha = 90^\circ$  being excluded. At smaller deadrise angles than those in figures 4 and 5, a comparison was carried between our  $C_p$  results and those shown in Zhao & Faltinsen (1993) for  $\alpha = 86^\circ$ . In this case we note a maximum deviation of about 10% which occurs at the wall. Table 1 presents a comparison of the results of the present procedure with those obtained by a similarity solution, an asymptotic approach and the boundary element method. In addition the calculated values of the kinetic energy of the flow and of the jets are shown. One can see the increasing importance of the momentum and energy associated with the jets as  $\alpha$  increases.

On the specific point of the energy balance for the impact of a symmetric body, a general discussion appears in Molin, Cointe & Fontaine (1996). In accordance with this last reference the energy going into the jets tends to be equal to the kinetic energy of the bulk of the fluid as the deadrise angle decreases.

$\alpha$ (deg.)	$C_{p_{max}}$				$(x_{max} - 1)$			
	Simil.	Asymp.	BE	Present results	Simil.	Asymp.	BE	Present results
50	3.266	3.50	3.26	3.5260	0.2866	0.5708	0.245	0.2687
60	6.927	7.40	6.94	7.1127	0.4243	0.5708	0.400	0.3655
65	10.691	11.35	10.9	10.622	0.4709	0.5708	0.443	0.4257
70	17.774	18.63	18.2	17.370	0.5087	0.5708	0.488	0.4728
75	33.271	34.37	32.8	32.654	0.5361	0.5708	0.533	0.5158
80	77.847	79.36	80.2	78.805	0.5556	0.5708	0.555	0.5619
82.5	140.587	142.36	148.3	146.422	0.5623	0.5708	0.558	0.5691
86	503.030	504.61	521.4	512.324	0.5695	0.5708	0.571	0.5708

$\alpha$ (deg.)	$F_x$				$E_{kin}$	$E_{jets}/E_{kin}$
	Simil.	Asymp.	BE	Present results		
50	5.477	8.322	5.31	5.7154	3.541	0.6140
60	14.139	18.747	13.9	16.168	9.424	0.7154
65	23.657	29.765	23.7	25.829	14.448	0.7877
70	42.485	50.639	43.0	44.020	23.714	0.8562
75	85.522	96.879	85.5	83.841	43.756	0.9161
80	213.98	231.973	220.8	202.125	104.230	0.9622
82.5	399.816	423.735	417.9	401.343	192.78	0.9788
86	1503.638	1540.506	1491.8	1487.321	744.14	0.9987

TABLE 1. Dimensionless slamming parameters vs.  $\alpha$ . Comparison of maximum pressure coefficient and its location  $x_{max}$ , and of vertical force  $F_x$  as obtained in a similar solution, an asymptotic analysis, a nonlinear boundary element method BE and the present procedure.  $E_{kin}$ , the kinetic energy of the bulk of the fluid, and  $E_{jets}$ , kinetic energy lost in the jets are also shown. Data for all but the present results are from Zhao & Faltinsen (1993).

When the case with a sideslip is considered one finds that the solution for the attached case is not always possible. In particular, a limit value of  $\beta$  exists for each  $\alpha$ , namely  $\beta^*$ , such that for  $\beta > \beta^*$  the only possible solution corresponds to separated flow. In order to obtain  $\beta^*$  from (2.6)–(2.13) we calculated the Jacobian  $\partial R_i / \partial q_j$  corresponding to the solutions of the problem. Here  $q_j$  represents the generic variable on which  $R$  depends. Then  $\beta^*$  is obtained when the determinant of  $\partial R_i / \partial q_j$  vanishes. As expected and with reference to figure 6 we note that  $\beta^*$  increases with  $\alpha$ .

Figure 7 shows the solutions of the flow field in the case of sideslip  $\beta = 4^\circ$ , for  $\alpha = 60^\circ$  and  $70^\circ$ , when the flow is attached to both walls. The corresponding distributions of the pressure coefficient are given in figure 8 together with the results for the symmetric case. On the windward wall the free surface rises higher than on the leeward wall and on the leeward side the pressure coefficient reaches a maximum value which is close to but greater than that of the symmetric case. When the flow separates from the wedge then, as already mentioned, the problem reduces to that of a flat plate which enters the liquid at an angle  $\beta$ . Figures 9 and 10 show the flow field for  $\beta = 4^\circ$  and  $\alpha = 60^\circ$ , and the corresponding distribution of the pressure coefficient, respectively. In comparison with the symmetric case both the maximum value  $C_{p_{max}}$  and the entire  $C_p$  distribution show noticeable differences. Furthermore the free surface on the downstream side and close to the wall falls below the unperturbed surface.

When the inertia force is calculated from the displaced virtual mass, one obtains values which approximate within a 15% error the von Kármán (1929) results which

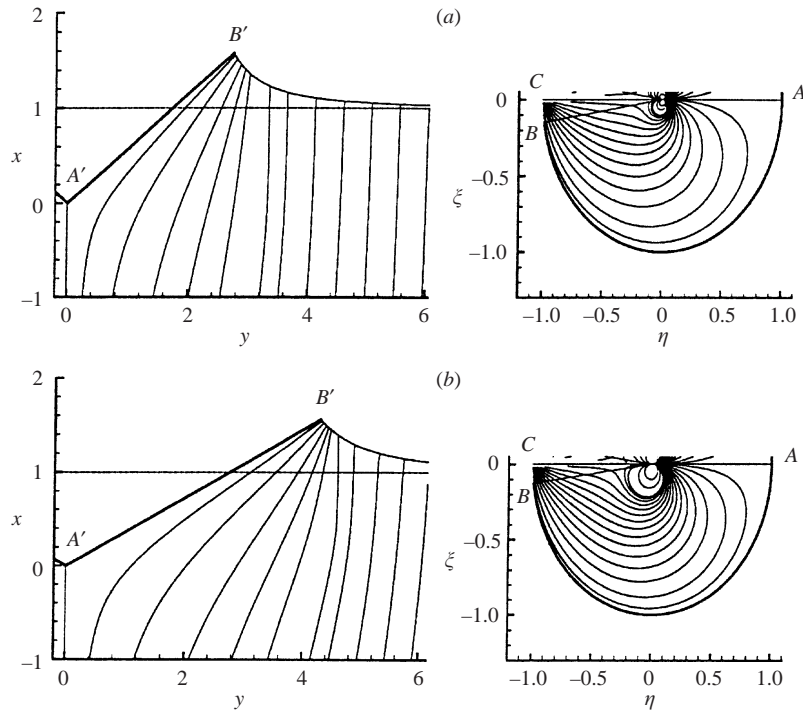

FIGURE 4. Symmetrical flow field,  $\alpha = 60^\circ$  (a),  $\alpha = 70^\circ$  (b).

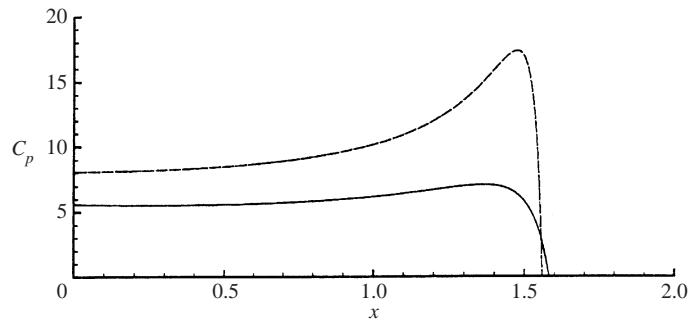

FIGURE 5. Symmetrical pressure distribution,  $\alpha = 60^\circ$  (continuous line),  $\alpha = 70^\circ$  (dashed line).

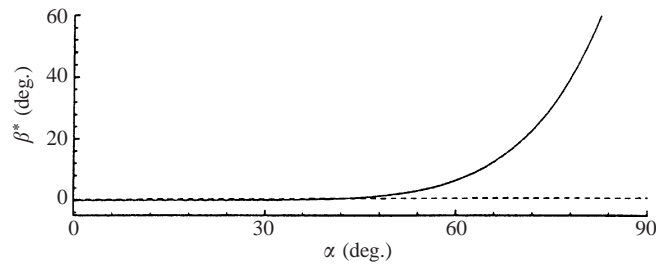

FIGURE 6. Values of the sideslip angle for the onset of separation  $\beta^*$  vs. the wedge angle  $\alpha$ . Above the line the flow separates from one side.

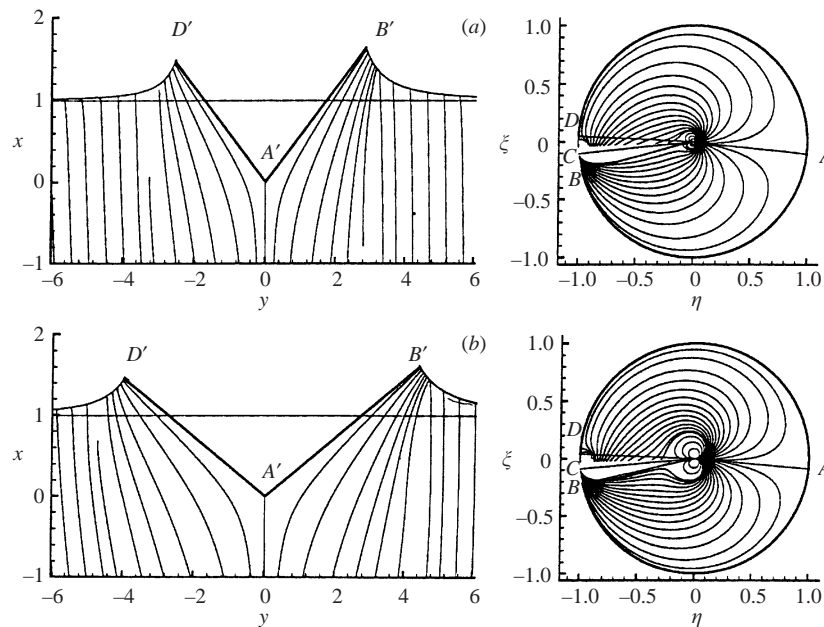

FIGURE 7. Unsymmetrical attached flow field: iso- $\psi$  line distributions in the physical and in the transformed plane,  $\alpha = 60^\circ$ ,  $\beta = 4^\circ$  (a);  $\alpha = 70^\circ$ ,  $\beta = 4^\circ$  (b).

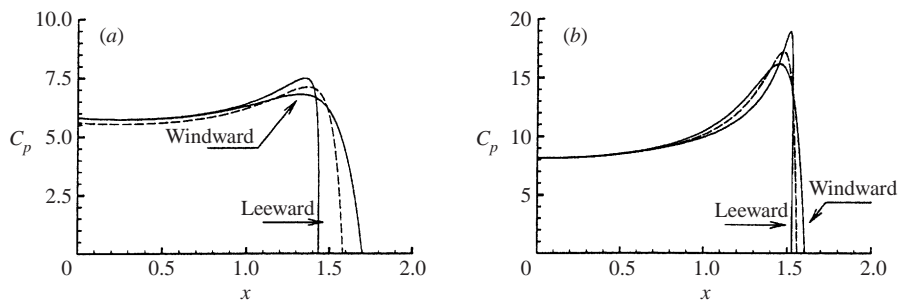

FIGURE 8. Pressure distribution for attached flow,  $\alpha = 60^\circ$  (a),  $\alpha = 70^\circ$  (b),  $\beta = 0$  (dashed lines),  $\beta = 4^\circ$  (continuous lines).

are evaluated with reference to the mass contained in a cylindrical volume having diameter equal to  $\tan \alpha$ .

Figure 10 shows a comparison between the pressure coefficient distributions on the wall for  $\alpha = 60^\circ$  and  $\beta = 10^\circ$  as calculated by our method and by von Kármán's approximation. In table 2, for  $\alpha = 60^\circ$  and at different  $\beta$ , the total force on the wet side of the wedge is reported together with the corresponding von Kármán values. Higher-order approximations of the flat-plate virtual mass, such as the one discussed in Meyerhoff (1970), are not considered here.

### 5. Conclusion

We conclude by summarizing the characteristics of the present approach. The Laplace equation is supposed to hold, after the introduction of similar variables gives a steady expression for the flow field. Then the physical aspects are modelled

$\beta$ (deg.)	Present results	von Kármán's results
4	5.415	4.692
6	5.382	4.664
8	5.336	4.620
10	5.277	4.573

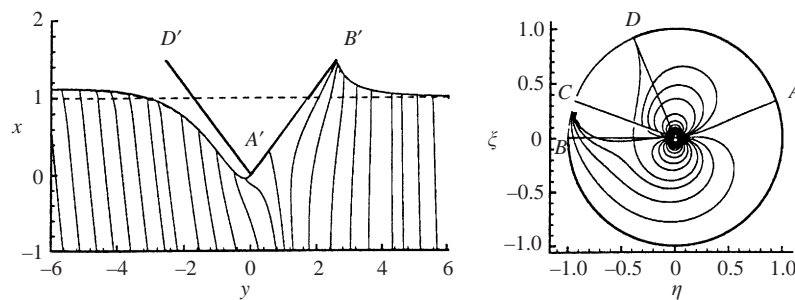
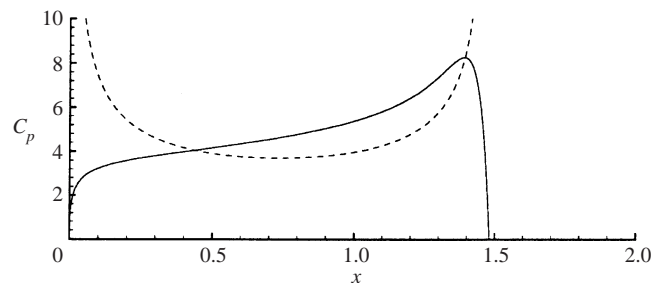
TABLE 2. Values of the total force on the wet side of the wedge for a separated flow,  $\alpha = 60^\circ$ .FIGURE 9. Separated flow field.  $\alpha = 60^\circ$  and  $\beta = 10^\circ$ : iso- $\psi$  line distributions in the physical and in the transformed plane.FIGURE 10. Pressure distribution for the separated flow,  $\alpha = 60^\circ$ ,  $\beta = 10^\circ$ : von Kármán's theory (dashed line), present method (continuous line).

by a suitable choice of singularities of the potential function in a translational potential. Following a conformal transformation, the main characteristics of the flow in the transformed plane are found by solving a system of algebraic equations for the singularities by an optimization procedure and the shape of the free surface is formally obtained by quadrature, although an easy way to practically compute it is based on a Runge-Kutta method. An important aspect of the model is the fact that the laws of mass continuity, momentum balance and energy conservation are enforced. The solutions were tested against existing data with excellent results. The method can be applied to the entire range of wedge angles, except for  $\alpha = 0$  and  $\alpha = 90^\circ$ , and takes easily into account a possible sideslip with and without separation.

The authors are indebted to the referees for their useful comments. This work was partially supported by the Italian Ministry for the Universities and Scientific and Technological Research.

## REFERENCES

- BIRKHOFF, G. & ZARANTONELLO, E. H. 1957 *Jets, Wakes and Cavities*. Academic.
- CARCATERRA, A. & CIAPPI, E. 2000 Prediction of the compressible stage slamming force on rigid and elastic systems impacting on the water surface. *Nonlinear Dyn.* **21**, 193–220.
- CISOTTI, U. 1921 *Idromeccanica piana*. Libreria Editrice Politecnica Tamburini, Milano.
- COINTE, R. 1987 Two-dimensional solid impact. *J. Offshore Mech. and Arctic Engng* **111**, 109–114.
- COINTE, R. 1991 Free-surface flows close to a surface piercing body. In *Mathematical Approaches in Hydrodynamics* (ed. T. Milhoh), pp. 319–334. SIAM.
- DOBROVOL'SKAYA, Z. N. 1969 On some problem of similarity flow of fluid with a free surface. *J. Appl. Mech.* **36**, 805–829.
- FALTINSEN, O. 1993 On seakeeping of conventional and high-speed vessels. *J. Ship Res.* **37**, 87–101.
- FALTINSEN, O. & ZHAO, R. 1997 Water entry of ship section and axisymmetric bodies. In *High Speed Body Motion in Water, AGARD Rep.* 827, pp. 24-1–24-11.
- FONTAINE, E. & COINTE, R. 1997 Asymptotic theories of incompressible water entry. In *High Speed Body Motion in Water, AGARD Rep.* 827, pp. 25-1–25-9.
- FRAENKEL, L. E. & MCLEOD, J. B. 1997 Some results for the entry of a blunt wedge into water. *Phil. Trans. R. Soc. Lond. A* **355**, 523–535.
- HOWISON, S. D., OCKENDON, J. R. & WILSON, S. K. 1991 Incompressible water-entry problems at small deadrise angles. *J. Fluid Mech.* **222**, 215–230.
- HUGHES, O. F. 1972 Solution of the wedge entry problem by numerical conformal mapping. *J. Fluid Mech.* **56**, 173–192.
- IAFRATI, A., CARCATERRA, A., CIAPPI, E. & CAMPANA, E. F. 2000 Hydroelastic analysis of a simple oscillator impacting the free surface. *J. Ship Res.* **44**, 278–289.
- VON KÁRMÁN, TH. 1929 The impact of seaplane floats during landing. *NACA Rep.* 321.
- KOROBKIN, A. A. 1992 Blunt body impact on a compressible liquid surface. *J. Fluid Mech.* **244**, 437–453.
- KOROBKIN, A. A. & PUKHNACHOV, V. V. 1988 Initial stage of water impact. *Annu. Rev. Fluid Mech.* **20**, 159–185.
- MACKIE, A. G. 1962 A linearized theory of the water entry problem. *Q. J. Mech. Appl. Maths* **2**, 137–151.
- MEYERHOFF, W. K. 1970 Added masses of thin rectangular plates calculated from potential theory. *J. Ship Res.* June 1970, 100–111.
- MOGHISHI, M. & SQUIRE, P. T. 1981 An experimental investigation of the initial force of impact on a sphere striking a liquid surface. *J. Fluid Mech.* **108**, 133–146.
- MOLIN, B., COINTE, R. & FONTAINE, E. 1996 On energy arguments applied to the slamming force. In *Proc. Eleventh Intl Workshop on Water Waves and Floating Bodies*.
- MORGAN, J. D. 1994 Codimension-two free boundary problems, pp. 37–40. PhD Thesis, Oxford.
- NUMERICAL ALGORITHMS GROUP 1991 *The NAG Fortran Library Manual, Mark 15*, Oxford, UK.
- SKALAK, R. & FEIT, D. 1966 Impact on the surface of a compressible fluid. *J. Engng Indust.* **88**, 325–331.
- TOYAMA, Y. 1993 Two-dimensional water impact of unsymmetrical bodies. *J. Naval Arch.* **173**, 285–291.
- TREFETHEN, L. M. & PANTON, R. 1990 Some unanswered questions in fluid mechanics. *Appl. Mech. Rev.* **43**, 153–170.
- WAGNER, H. 1932 Über Stoß und Gleitvorgänge an der Oberfläche von Flüssigkeiten. *Z. Angew. Math. Mech.* **12**, 193–215.
- ZHAO, R. & FALTINSEN, O. 1993 Water entry of two-dimensional bodies. *J. Fluid Mech.* **246**, 593–612.
- ZHAO, R., FALTINSEN, O. & AARSNES, J. 1997 Water entry of arbitrary two-dimensional sections with and without separation. In *Proc. Twenty-first Symp. on Naval Hydrodynamics*, pp. 408–423.